

CARVER CLAMPS



## BUTTRESS CLAMPS

The Buttress Clamp holds press tools on all types of power press and makes it a popular choice for drilling, grinding, machining, lathe faceplates and planing applications. It has the ability to clamp work from 0-75mm (3") deep.

One key feature is the self-aligning captive pivot which ensures a constant clamping ratio between workpiece and table, whilst its H-shaped heads four-point contact resists the tendency for the workpiece to rotate giving you added stability.

The Buttress Clamp is available in three sizes – standard, medium and heavy Duty.

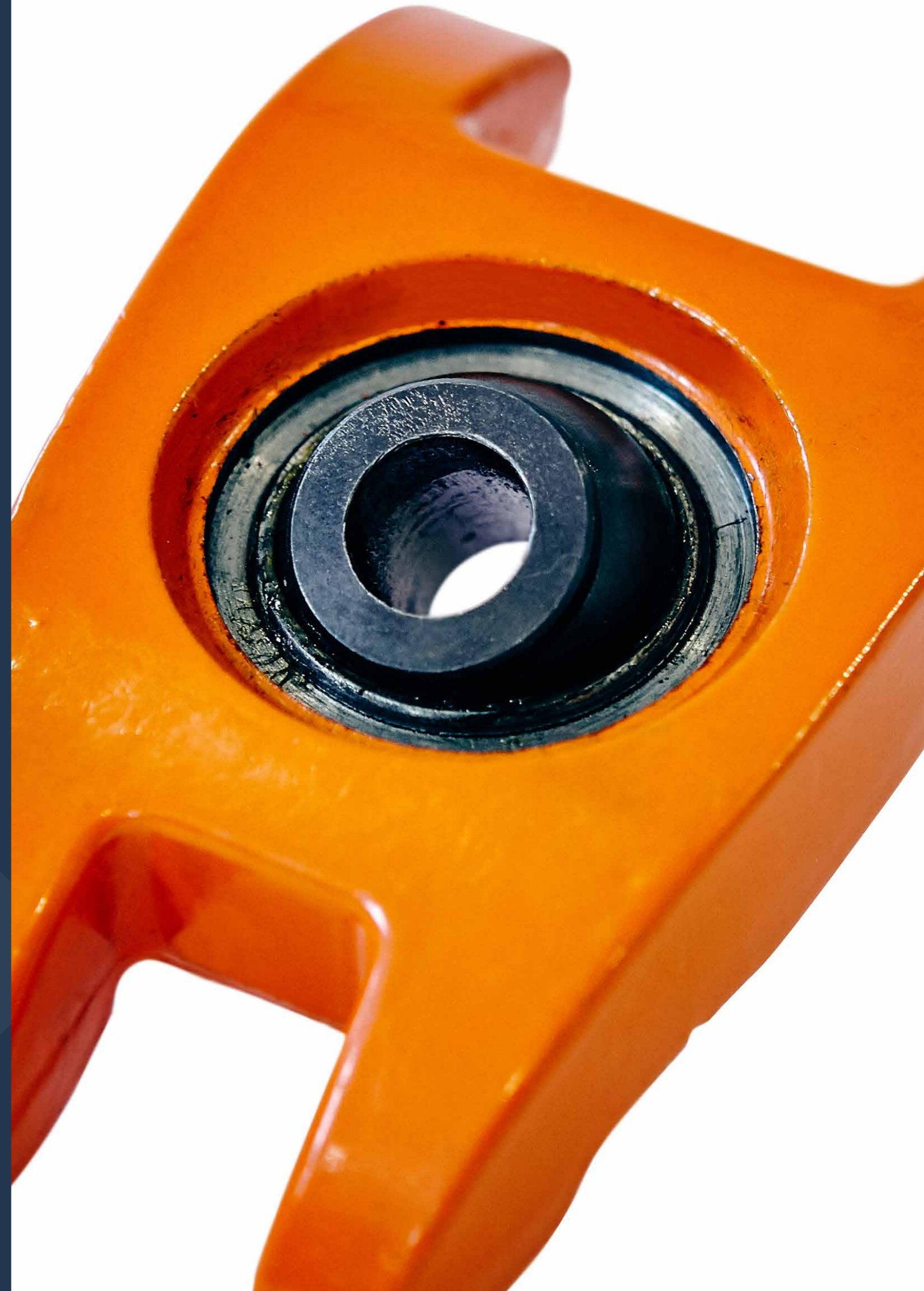





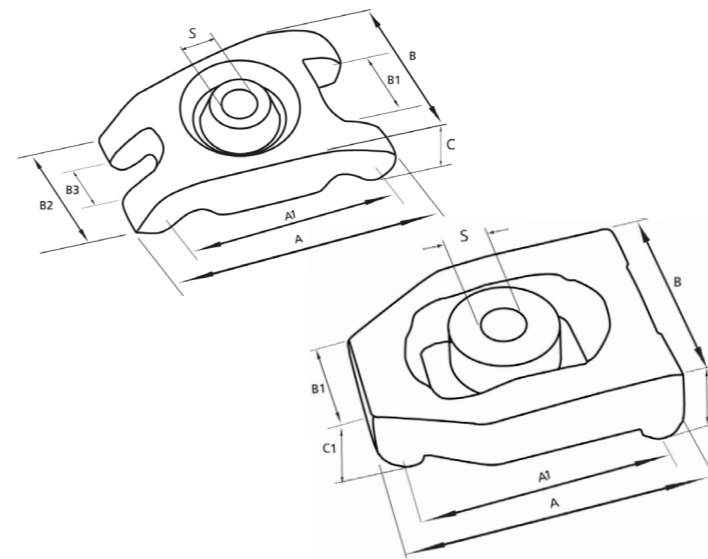



# BUTTRESS CLAMPS

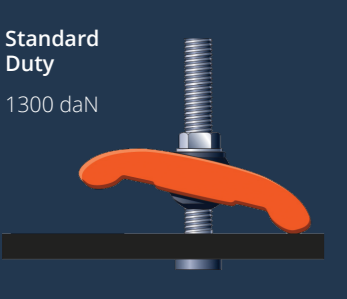

1 daN=1kgf / 1 daN=2.2lbf / 1 daN=10 N

- ❖ Holds press tools on all types of power press.
- ❖ Clamps work up to 75mm (3") deep to drilling machines and lathe faceplates.
- ❖ Constant clamping force ratio between workpiece and table, thanks to self-aligning captive pivot.
- ❖ h-shaped head's 4-point contact resists tendency for workpiece to rotate.

	Part No.	Model No.	Max Safe Working Height mm (Inch)	Max Fixing Bolt Diameter mm (Inch)	Clamp Weight kg
<b>Standard Duty</b> 1300 daN 	C301160	T614-0	25 (1)	M12 (1/2)	0.6
<b>Medium Duty</b> 6250 daN 	C301161	T614-1	57 (2.1/4)	M16 (5/8) or M20 (3/4)	2.7
<b>Heavy Duty</b> 8000 daN 	C301162	T614-2	75 (3)	M24 (1)	4.3

Model No.	A mm	A1 mm	A2 mm	B mm	B2 mm	B3 mm	C mm	C1 mm	S mm
<b>T614-0</b> 	110	90	66	36	40	20	26	-	13
<b>T614-1</b> 	160	134	100	53	65	29	46	-	21
<b>T614-2</b> 	170	148	130	65	-	-	50	40	26